



(11) **EP 1 259 105 B2**

(12) **NEW EUROPEAN PATENT SPECIFICATION**  
After opposition procedure

(45) Date of publication and mention  
of the opposition decision:  
**12.08.2009 Bulletin 2009/33**

(45) Mention of the grant of the patent:  
**12.04.2006 Bulletin 2006/15**

(21) Application number: **01904067.4**

(22) Date of filing: **31.01.2001**

(51) Int Cl.:  
**A01B 15/06 (2006.01) A01B 23/02 (2006.01)**

(86) International application number:  
**PCT/GB2001/000387**

(87) International publication number:  
**WO 2001/056360 (09.08.2001 Gazette 2001/32)**

(54) **WORKING TOOL WITH REPLACEABLE WORKING BIT**

**ARBEITSGERÄT MIT AUSWECHSELBARER SPITZE**

**OUTIL D'USINAGE A EXTREMITÉ REMPLACABLE**

(84) Designated Contracting States:  
**AT BE CH CY DE DK ES FI FR GB GR IE IT LI LU  
MC NL PT SE TR**  
Designated Extension States:  
**LT LV**

(30) Priority: **04.02.2000 GB 0002536**  
**31.05.2000 GB 0013050**

(43) Date of publication of application:  
**27.11.2002 Bulletin 2002/48**

(73) Proprietor: **KVERNELAND KLEPP AS**  
**N-4344 Kverneland (NO)**

(72) Inventor: **SKJAEVELAND, Magne**  
**N-4344 Kverneland (NO)**

(74) Representative: **Raynor, Simon Mark et al**  
**Urquhart-Dykes & Lord LLP**  
**Midsummer House**  
**413 Midsummer Boulevard**  
**Central Milton Keynes MK9 3BN (GB)**

(56) References cited:

<b>DE-A- 2 655 792</b>	<b>DE-A- 3 340 429</b>
<b>DE-A- 3 628 910</b>	<b>DE-A- 3 718 819</b>
<b>DE-B- 1 192 436</b>	<b>US-A- 3 082 555</b>
<b>US-A- 4 269 274</b>	<b>US-A- 4 415 042</b>
<b>US-A- 4 638 868</b>	<b>US-A- 4 754 816</b>
<b>US-A- 4 871 032</b>	<b>US-A- 4 905 386</b>
<b>US-A- 5 465 796</b>	<b>US-A- 5 711 378</b>

**EP 1 259 105 B2**

## Description

**[0001]** This invention relates to a replaceable working bit according to the preamble of claim 1 and as described in US-A-4754816 and a working tool with a replaceable working bit,

**[0002]** The invention is concerned generally with a working tool, which necessarily is provided with one or more working edge or face which is designed to work on a particular material, and which therefore is exposed to wearing action over a period of time.

**[0003]** However, the invention has been developed primarily in connection with a working tool which is capable of working on soil or similar material e.g. sand, gravel, stone, rubble, and which usually has a working edge to engage the working material concerned. The working edge will be subject to wear over a greater or lesser period of time, depending upon the required operation, and the material being handled.

**[0004]** In some blade-type of working tools, it is acceptable to carry out sharpening of the edge as it becomes worn, and this can be done a number of times (by progressive erosion into the main body of the tool) but eventually the entire tool has to be scrapped. In other working tools, it is known to provide replaceable working edges, which are secured to the main body of the tool by threaded fasteners e.g. bolts or screws, and which are sacrificial, in the sense that the working edges protect the main body of the tool from wear (which is the expensive component), and which are replaced when an unacceptable level of wear has occurred in the replaceable part.

**[0005]** In connection with soil working tools for use in agriculture, there are many examples of working elements or working "bits" which are replaceably mounted on the main body of the tool concerned e.g. a "point" on the share of a plough, a knife on a plough body, or a tip of a cultivator tine.

**[0006]** In most of these arrangements, it is usual to mount the working element in position by means of two separate threaded fasteners. This gives a robust mounting of the elements, and by reason of using two separate fasteners, the element is well able to resist any twisting or turning moments which may be applied to the element in service, in addition to providing shear resistance to any direct forces tending to separate the element from the tool.

**[0007]** Evidently, when it become necessary to replace a worn element, the two fasteners have to be released, and a replacement element then installed in place. If this is carried out "in the field", this is a time consuming and difficult task, especially, as is often the case, the fasteners or nut fixings have become damaged, rusted or otherwise become difficult to release. The same will apply in respect of routine maintenance carried out prior to use. In extreme cases, it is necessary to use a cutting torch to release the fasteners.

**[0008]** Bearing in mind that a large cultivator might

have up to sixty separate cultivator tines (each with its own replaceable tip), it can be a major operation to replace a full set of worn tips.

**[0009]** In extreme soil conditions e.g. heavy clay plus flints, a new set of cultivator tips can become worn within three hours and then need replacement. A tractor to propel such large cultivators might cost of the order of £200,000, and is therefore an extremely expensive piece of capital equipment, and possible "downtime" of the order of three hours represents a serious under utilisation of such a high capital cost item.

**[0010]** With a view to simplify the assembly and dis-assembly of replaceable wearing parts, it is known to provide a mounting arrangement on the main body of the tool which only requires a single fastener, but necessarily this requires the provision of a suitably shaped seating which holds the wearing part captive against rotation about the axis of the single fastener.

**[0011]** One example of such a known mounting arrangement comprises an assembly of a replaceable wearing part on a main body of a cultivator tine, in which the wearing part has a rectangular body which merges into a V-shaped tip at one end, and on its opposite end it has a narrow projecting lug. A single fastener is taken through the body and through a mounting hole in the tine, and a shaped socket or receiving recess also in the tine receives the projecting lug in order to provide resistance to any turning action which may be applied in service to the tip and tending to rotate the tip about the axis of the fastener.

**[0012]** In this known arrangement of replaceable cultivator tip, there is still the disadvantage of assembly and dis-assembly of the fastener, but in addition the projecting lug only forms a narrow prolongation of the main body of the tip i.e. the main body is much wider than the lug, and the lug is therefore the sole means of resisting turning forces applied to the tip about the axis of the fastener. Therefore, this construction relies for its strength on the narrow lug, and on which highly concentrated stresses may be generated in service which may result in premature failure.

**[0013]** The invention therefore seeks to provide a novel arrangement of replaceable wear part or bit for mounting on a leading edge of a working tool, and which can be mounted in a working position on the tool, and be secured against displacement from the working position, without need for threaded or other separate removable fastener (s).

**[0014]** According to one aspect of the invention there is provided a replaceable wear part for mounting on a leading edge of a working tool according to claim 1.

**[0015]** Therefore, a replaceable wear part according to the invention can be driven e.g. by a hammer to take-up its working position, and the co-operative guide formations allow the wear part to slide in a direction generally perpendicular to the leading edge. The guide formations are arranged to exert a wedging action on the wear part, so that the greater the distance travelled, the strong-

er will be the frictional engagement forces acting between the guide formations.

**[0016]** In a preferred arrangement, the guide formations in the leading edge of the tool form a socket whose width reduces with distance perpendicularly inwardly of the leading edge, so that a progressively increasing wedging force can act on a wear part as it is driven internally of the socket.

**[0017]** The socket may be defined between a pair of opposed side walls which are convergent or taper, and the wear part has opposed external side faces which are also convergent or taper, but to a greater extent than the tapering of the side walls of the socket, so that an increasing wedging force is generated therebetween as the wear part is driven to its working position, whereby also the frictional resistance against possible displacement increases progressively.

**[0018]** The co-operative guide formations preferably also have an interengagement which opposes any relative rotation of the wear part about its longitudinal axis.

**[0019]** The walls or faces defining the guide formations are be of matching V-shape in cross section, such as to oppose rotation of the wear part about its longitudinal axis, and relative to the leading edge.

**[0020]** Preferably, the invention comprises an assembly of the replaceable wear part and the working tool in combination.

**[0021]** The wear part may comprise a working bit to be mounted on a transversely extending leading edge of an agricultural tool, such as a "point" (preferably a reversible point), a ploughshare, or a cultivator tine. However, the invention may be applied to other types of working tool than agricultural tools e.g. an excavator bucket (front or rear mounted), or a loading shovel, each having a leading edge provided with excavator teeth mounted thereon along the length of the leading edge, in which each excavator tooth comprises a replaceable wear part according to the invention.

**[0022]** Preferred embodiments of the invention will now be described in detail, by way of example only, with reference to the accompanying drawings, in which:

Figure 1 is a plan view of a first embodiment of the invention in the form of a ploughshare in assembly with a wear replaceable part, or "bit" which is force-fitted in order to take-up a mounting position in the leading edge of the share;

Figure 2 is a side view of the assembly;

Figure 3 is a section taken on the section line A-A in Figure 1, and showing the engagement between the external side faces of a mounting portion of the wear part, and the side profiles of the socket defined in the leading edge of the share;

Figure 4 is a plan view of a second embodiment of the invention in the form of a replaceable tine point tip for mounting on the end of a tine, shown in exploded, unassembled form;

Figure 5 is a side view of the tine point tip shown in

Figure 4;

Figure 6 is a plan view of another example of tine point tip after it has been driven to a working position mounted on the end of a cultivator tine;

Figure 7 is a side view corresponding to Figure 6;

Figure 8 is a cross section taken on the section line A-A in Figure 6, and showing the slidable interengagement between the external side faces of a mounting portion of the tine point tip, and the side profiles of the socket provided in the leading end of the cultivator tine which receives the mounting portion;

Figure 9 is a plan view of the leading end of a cultivator tine, showing the recess or socket which receives the mounting portion of the tine point tip (of Figure 4 or 6);

Figure 10 is an end view showing the side profiles of the socket;

Figure 11 is a plan view of a third embodiment of the invention, showing a replaceable wear bit mounted (by force-fit) at the leading end of an inclined leading edge of a reversible point;

Figure 12 is a plan view of a device not according to the invention; and,

Figure 13 is a side view of the device shown in Figure 12.

**[0023]** Referring now to the drawings, there will be described preferred embodiments of replaceable working part or bit according to the invention, and adapted for mounting on a working tool having one or more working edge or face which is designed to work on a particular material, and which is exposed to wearing action over a period of time.

**[0024]** The preferred embodiments which will be described comprise soil working tools for use in agriculture, but it should be understood that the invention has wider application, and can be applied to replaceable working bits per se, and to other types and combinations of working tool requiring replaceable working bits to be mounted thereon, and without need for threaded or other fasteners to assemble and disassemble the combination.

**[0025]** Referring first to Figures 1 to 3, a first embodiment of the invention is illustrated, and which comprises the combination of a plough share (and a replaceable wear part or "bit"), designated generally by reference 10, and which has usual mounting holes 11 along its lower edge, whereby the share 10 can be mounted on a plough, and when mounted in position, it is the transversely extending leading end or edge 12 of the share 10 which is the frontal part of the share and which first engages the soil during forward movement of the plough body. A replaceable wear part or bit, designated generally by reference 13, is mounted (by force-fit) in the leading end 12 of the share 10. so that it takes up a working position, after being driven by a force extending generally perpendicular to the leading edge 12 e.g. by a hammer. In the working position, the wear part 13 is secured against dis-

placement from the working position by frictional inter-engagement between co-operative guide formations on the wear bit 13 and a suitable receiving formation provided in the leading edge, and without need for threaded or other separate removable fasteners.

**[0026]** In the illustrated embodiment, a receiving socket 14 is formed in the leading end region 15 of the share 10, and socket 14 is defined by a pair of opposed profiled side edges 16 (see Figure 3) which converge or taper, as can be seen in Figure 1, whereby a progressively increasing wedging action is applied to a projecting mounting portion 17 of the wear bit 13.

**[0027]** The mounting portion 17 has opposed external side edges 18, which also are convergent, but to a lesser extent than the convergence of the side edges 16 of the socket 14, whereby progressive axial movement of the mounting portion 17 inwardly of the socket 14 results in a progressively increasing wedging action, and frictional force acting between the co-operative guide formations (the internal side faces 16 of socket 14 and the external sides 18 of mounting portion 17).

**[0028]** The wear bit 13 is made of suitable hard wearing material e.g. forged metal, and clearly the greater part of any wearing action applied to the combination of the share 10 and bit 13 will be borne by the bit 13, since it is the first part of the combination to engage unworked soil. The working forces applied to the bit 13 will generally tend to force the mounting portion 17 still further into the socket 14, and therefore during normal operation, there is no risk of the bit 13 becoming dislodged from its mounting position. Evidently, any forces applied to the bit 13 other than axially extending forces, may apply a turning moment to the bit 13, but any rotation of the bit 13 in the socket 14 will be resisted by the way in which the guide formations inter-engage. Furthermore, any possible tendency of the bit 13 to rotate about its general longitudinal axis 19 will be borne by the co-operative inter-engagement between each external side 18 of mounting portion 17 and the corresponding internal side edges 16. As can be seen clearly from Figure 3, each of the co-operative guide formations is V-shaped, and clearly the inter-engagement will be such as to strongly oppose any rotational forces applied to the wear bit 13, about the longitudinal axis 19.

**[0029]** In use of the combination of the share 10 and the wear bit 13, the share 10 will be exposed to wearing action as it moves through the soil, but the major part of any wearing forces will be borne by the wear bit 13, and which will be made of suitable wear resistant material, and this in combination with the robust but simple mode of mounting in position, will mean that the wear bit is exposed to the major wearing action, thereby prolonging the effective life of the share 10.

**[0030]** The wear bit 13 can be easily mounted in position, by simple application of a driving force e.g. by a hammer, which force fits the mounting portion 17 into the socket 14. However, the wear bit 13 will be exposed to wearing action over a period of time, and when an unac-

ceptable level of wear has occurred, it is a simple matter to dis-assemble the combination, by insertion of a wedging tool (not shown) between the inboard end 20 of the mounting portion 17 and the inner end 21 of the socket 14. Therefore, replacement of a worn bit 13 can take place easily, either during routine maintenance, or in the field when necessary, and without need to release threaded fasteners as used in known arrangements.

**[0031]** Evidently, the combination shown in Figures 1 to 3, is a socket and projection type of inter-fit, and in which the projection is provided on the wear part 13 and the socket is provided in the leading end of the share 10.

**[0032]** Referring now to Figures 4 and 5, there is shown a second embodiment of the invention, applied to a cultivator tine (see also Figures 9 and 10), and replaceable tine point tip. The tip is shown in Figure 4, and designated generally by reference 22, and having a rectangular main body 23, and which is provided with a V-shaped tip 24 at one end, and a rearwardly projecting mounting portion 25 at its opposite end. The mounting portion 25 performs a similar function to mounting portion 17 of wear bit 13 in the first embodiment, and is driven into frictional engagement in a socket or recess 26 formed in a lower mounting end 27 of a cultivator tine (shown in exploded, unassembled form). The inter-engagement between the mounting portion 25 and recess 26 is generally the same as in the first embodiment, and after driving of the tine point tip 22 (which is a further example of a replaceable wear part or bit) to a working position in the recess 26, the frictional inter-engagement between the co-operative guide formations is sufficient to hold the tip 22 in the working position. Also, as in the previous embodiment, there is resistance to any turning moments which may be applied in service to the tip 22, by the co-operative engagement between the guide formations.

**[0033]** An alternative type of wear part 22a is shown in Figures 6 to 8, in assembly with a cultivator tine or other agricultural tool 27a.

**[0034]** Referring to Figure 11, a third embodiment of replaceable wear part or bit is shown, for assembly with a reversible point, designated generally by reference 30. The point 30 has an inclined leading edge 31, and a replaceable wear bit 32 is driven e.g. by a hammer, to take up the working position shown in Figure 11, within a recess or socket 33 provided in the leading end region 34 of the point 30. Again, co-operative guide formations are provided on the opposed inner side edges of the recess 33, and the opposed external sides of the wear bit 32, which provide required frictional engagement to hold the wear part 32 in the working position, after it has been driven to the working position by axial sliding movement. There is also resistance against any turning moments applied to the wear bit 32 in service.

**[0035]** It should be noted particularly from Figure 11 that the wear bit 32 is located at or close to the leading edge region 31a of the inclined leading edge 31 of the point 30. Therefore, in practice, virgin or unworked soil will be engaged first by the leading end 32a of the wear

bit 32, and since the wear bit 32 will be made of a material which is strongly resistant to abrasive action, it can have a long service life, and as it projects forwardly of the leading edge 31, even by a small amount, it will be exposed to the greatest wearing action of the unworked soil, and which loosens the soil, and which then undergoes further working action by continued forward movement of the leading edge 31.

**[0036]** The wear bit 32 is driven to the working position in the socket, and once an unacceptable level of wear has arisen, the wear bit 32 can be removed by driving a wedging tool (not shown) between the inner ends of the wear bit 32 and the recess 33 in which it is mounted.

**[0037]** The embodiments shown in the drawings are examples of the invention applied to agricultural tools, and replaceable wear parts or bits for use with such tools. However, the invention is applicable to other examples of working tools having a leading edge or face, exposed to a wearing action, such as the leading edge of an excavator bucket or shovel.

**[0038]** Usually, excavator buckets have digging teeth mounted along the leading edge, and at present the mounting of these teeth is by means of threaded fasteners, rivets and other similar fastenings. However, it should be understood that the concept of replaceable wear bits, without use of threaded fasteners, can be applied to digging teeth provided on excavator buckets and the like.

**[0039]** A device not according to the invention is illustrated in Figures 12 and 13, and comprises a holder 40, and a point 41 having a slidable inter-fit with the holder 40, by way of co-operative guide formations, and which allow the point 41 to be driven by a force extending generally perpendicular to the leading edge in order to take up a working position in which it is secured against displacement from the working position by frictional inter-engagement between the guide formations, and without need for threaded or other separate removable fasteners.

**[0040]** The device shown in Figures 12 and 13 is generally similar to the embodiments. Essentially, it comprises a holder of the type shown in Figure 9, and a point of the type shown in Figure 4. The holder 40 is mounted on a tine 42, and the holder 40 is in two parts, comprising a main part 43 forming a central holder, and to which the point 41 is detachably secured, and a rear / upper holder part 44 which is secured to the tine 42 via a single bolt 45. However, to prevent the wear holder part 44 from rotating about the bolt 45, and therefore wobbling in service, there is a sloping tongue 46 fitting into a corresponding notch or groove 47 in the main holder part 40.

## Claims

1. A replaceable wear part (13,22,22a,32,41) for mounting on a leading edge (12,27) of a working tool (10,27,30), said leading edge and said wear part having co-operative guide formations (16,18) ex-

tending generally perpendicular to the leading edge and which provide a socket and projection type of slidable inter-fit and allow the wear part to slide in a direction generally perpendicular to the leading edge, and are arranged to exert a wedging action on the wear part so that the greater the distance travelled, the stronger will be the frictional engagement forces acting between the guide formations, whereby the wear part can be driven by a force extending generally perpendicular to the leading edge in order to take up a working position in which it is secured against displacement from the working position by frictional inter-engagement between the guide formations (16,18) on the wear part and the leading edge, and without need for threaded or other separate removable fasteners, said co-operative guide formations (16,18) allowing the wear part (13) to slide in a direction generally perpendicular to the leading edge (12), and providing a wedge-type inter-engagement between the guide formations (16,18) such that the greater the distance travelled, the stronger will be the frictional engagement forces acting between the guide formations:

**characterised in that** the guide formations are defined by walls or faces (16,18) which are each of matching V-shape in cross section to oppose relative rotation of the wear part (13) about its longitudinal axis (19), the guide formations (18) of the wear part (13,22,22a,32,41) are provided on opposed edges of a rearwardly-projecting mounting portion (17,25,25a,32) of the wear part, and the guide formations (16) of the working tool are provided on opposed side walls of a socket portion of the working tool.

2. A replaceable wear part according to claim 1, and in combination with a working tool (10,27,30), in which the socket is defined between a pair of opposed side walls (16) which are convergent or taper, and the wear part (13) has opposed external side faces (18) which are also convergent or taper, but to a greater extent than the tapering of the side walls (16) of the socket, so that an increasing wedging force is generated therebetween as the wear part (13) is driven to its working position, whereby also the frictional resistance against possible displacement increases progressively.
3. A wear part according to any one of claims 1 to 2, and adapted to be mounted on a transversely extending leading edge of an agricultural tool, such as a point (30), a ploughshare (10), a cultivator tine (27), or a holding portion (27) of an agricultural tool.

## Patentansprüche

1. Austauschbares Verschleißteil (13, 22, 22a, 32, 41)

zur Montage an einer vorderen Kante (12, 27) eines Arbeitswerkzeugs (10, 27, 30), wobei die vordere Kante und das Verschleißteil zusammenwirkende Führungsanordnungen (16,18) aufweisen, welche sich im Allgemeinen senkrecht zu der vorderen Kante erstrecken und welche eine flanschartige und vorsprungsartige gleitende Passung bereitstellen und dem Verschleißteil ermöglichen, in einer im Wesentlichen zu der vorderen Kante senkrechten Richtung zu gleiten, und derart angeordnet sind, dass sie eine einkeilende Wirkung auf das Verschleißteil ausüben, so dass die Reibungseingriffskräfte, welche zwischen den Führungsanordnungen wirken, umso stärker sind, umso größer der zurückgelegte Abstand ist, wodurch das Verschleißteil durch eine Kraft getrieben werden kann, welche sich im Allgemeinen senkrecht zu der vorderen Kante erstreckt, um eine Arbeitsstellung einzunehmen, in welcher es sich fest gegenüber einer Verschiebung aus der Arbeitsstellung durch einen Reibungseingriff zwischen den Führungsanordnungen (16,18) auf dem Verschleißteil und der vorderen Kante befindet, und wobei keine mit einem Gewinde versehene oder andere separate entfernbare Befestigungsmittel notwendig sind, wobei die zusammenwirkenden Führungsanordnungen (16,18) ermöglichen, dass das Verschleißteil (13) in eine Richtung gleitet, welche im Allgemeinen senkrecht zu der vorderen Kante (12) ist, und wobei ein keilartiger Eingriff zwischen den Führungsanordnungen (16,18) vorhanden ist, so dass die Reibungseingriffskräfte, welche zwischen den Führungsanordnungen wirken, umso stärker sind, umso größer der zurückgelegte Abstand ist:

**dadurch gekennzeichnet, dass** die Führungsanordnungen durch Wände oder Flächen (16,18) definiert sind, welche eine passende V-Form im Querschnitt aufweisen, um einer relativen Drehung des Verschleißteiles (13) um seine Längsachse (19) entgegenzutreten, wobei die Führungsanordnungen (18) des Verschleißteiles (13, 22, 22a, 32, 41) auf gegenüberliegenden Kanten eines nach hinten hervorragenden Montageabschnitts (17, 25, 25a, 32) des Verschleißteiles vorhanden sind und wobei Führungsanordnungen (16) des Arbeitswerkzeugs auf gegenüberliegenden Seitenwänden eines Flanschabschnitts des Arbeitswerkzeugs vorhanden sind.

2. Austauschbares Verschleißteil nach Anspruch 1, und in Kombination mit einem Arbeitswerkzeug (10, 27, 30), in welchem der Flansch durch ein Paar gegenüberliegende Seitenwände (16) definiert ist, welche konvergent oder kegelförmig sind, und wobei das Verschleißteil (13) gegenüberliegende äußere Seitenflächen (18) aufweist, welche auch, aber mit einem geringeren Umfang als die Verjüngung der Seitenwände (16) des Flansches, konvergent oder kegelförmig sind, so dass eine sich erhöhende Ver-

keilkraft dazwischen erzeugt wird, wenn das Verschleißteil (13) zu seiner Arbeitsstellung getrieben wird, wodurch sich auch der Reibungswiderstand gegen eine mögliche Verschiebung fortschreitend erhöht.

3. Verschleißteil nach Anspruch 1 oder 2, und ausgestaltet, um sich auf einer quer erstreckenden vorderen Kante eines Landwirtschaftswerkzeugs zu erstrecken, wie zum Beispiel einem Anschlussstück (30), einer Pflugschar (10), einer Ackerfräsenzacke (27) oder einem Halteabschnitt (27) eines Landwirtschaftswerkzeugs.

### Revendications

1. Pièce d'usure remplaçable (13, 22, 22a, 32, 41) destinée à être montée sur un bord d'attaque (12, 27) d'un outil de travail (10, 27, 30), ledit bord d'attaque et ladite pièce d'usure ayant des formations de guidage (16, 18) coopérantes s'étendant sensiblement perpendiculairement au bord d'attaque et qui constituent un raccord mutuel coulissant de type à douille et à saillie et permettent à la pièce d'usure de coulisser dans une direction sensiblement perpendiculaire au bord d'attaque, et sont conçues pour exercer une action de coinçage sur la pièce d'usure de façon à ce que plus la distance parcourue est importante, plus les forces de mise en prise par frottement agissant entre les formations de guidage soient importantes, la partie d'usure pouvant être entraînée par une force s'exerçant sensiblement perpendiculairement au bord d'attaque afin d'adopter une position de travail dans laquelle elle ne peut pas quitter la position de travail par la mise en prise mutuelle par frottement entre les formations de guidage (16, 18) sur la pièce d'usure et le bord d'attaque, et sans nécessiter d'éléments de fixation filetés ou d'autres éléments de fixation détachables séparés, lesdites formations de guidage (16, 18) coopérantes permettant à la pièce d'usure (13) de coulisser dans une direction sensiblement perpendiculaire au bord d'attaque (12) et procurant une mise en prise mutuelle de type à coin entre les formations de guidage (16, 18), de façon à ce que plus la distance parcourue est importante, plus les forces de mise en prise par frottement agissant entre les formations de guidage sont importantes :

**caractérisée en ce que** les formations de guidage sont définies par des parois ou faces (16, 18) qui ont chacune une forme en V complémentaire en coupe pour s'opposer à la rotation relative de la pièce d'usure (13) autour de son axe longitudinal (19), les formations de guidage (18) de la pièce d'usure (13, 22, 22a, 32, 41) étant prévues sur les bords opposés d'une partie de montage dépassant vers l'arrière (17, 25, 25a, 32) de la pièce d'usure et les formations de

guidage (16) de l'outil de travail étant prévues sur des parois latérales opposées d'une partie femelle de l'outil de travail.

2. Pièce d'usure remplaçable selon la revendication 1 et en combinaison avec un outil de travail (10, 27, 30), dans laquelle la douille est définie entre une paire de parois latérales (16) opposées qui sont convergentes ou progressivement rétrécies, et la pièce d'usure (13) présente des faces latérales externes (18) opposées qui sont également convergentes ou progressivement rétrécies, mais selon une valeur supérieure au rétrécissement progressif des parois latérales (16) de la douille, de sorte qu'une force de coïncement croissante est générée entre elles lorsque la pièce d'usure (13) est entraînée dans sa position de travail, la résistance de frottement contre le déplacement possible augmentant également progressivement.
3. Pièce d'usure remplaçable selon l'une quelconque des revendications 1 à 2, et adaptée pour être montée sur un bord d'attaque s'étendant de manière transversale d'un outil agricole, tel qu'une pointe (30), un soc (10), une dent de cultivateur (27) ou une partie de support (27) d'un outil agricole.

5

10

15

20

25

30

35

40

45

50

55

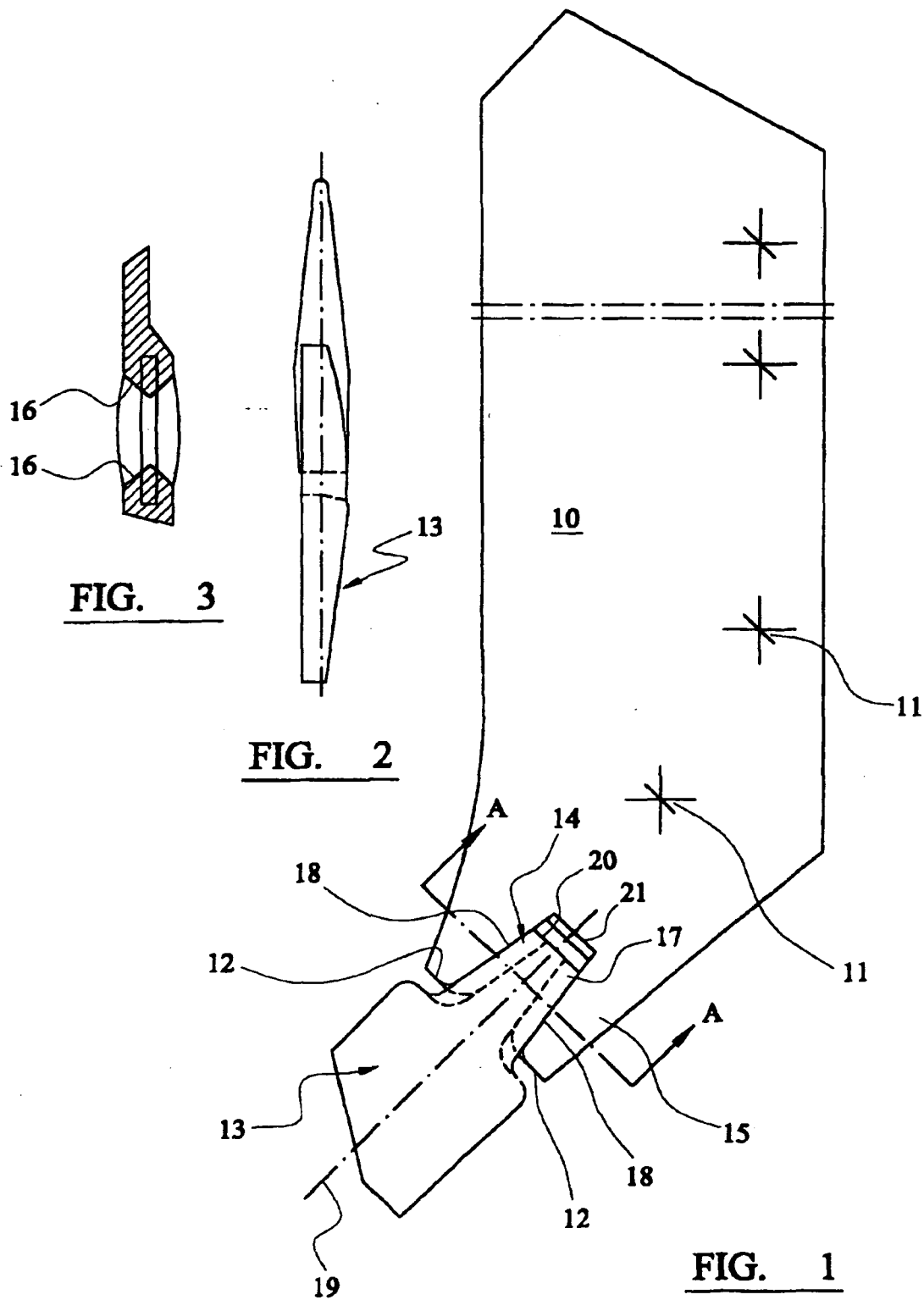



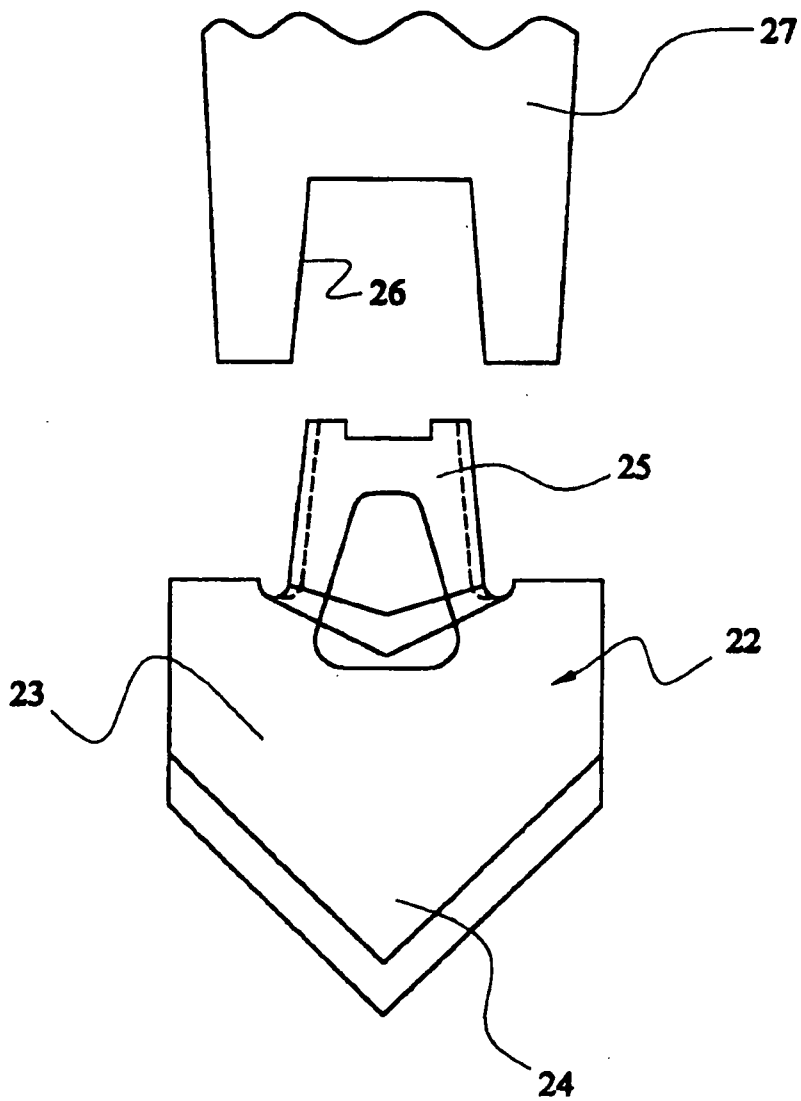

FIG. 4

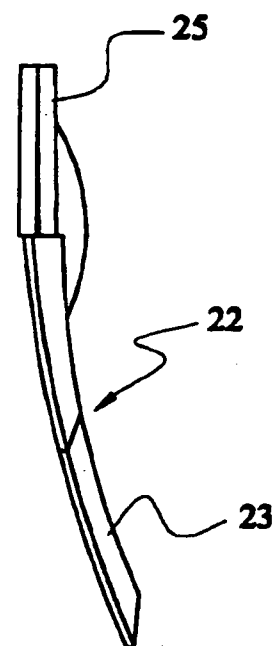

FIG. 5

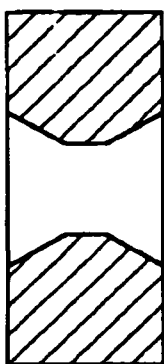

FIG. 8

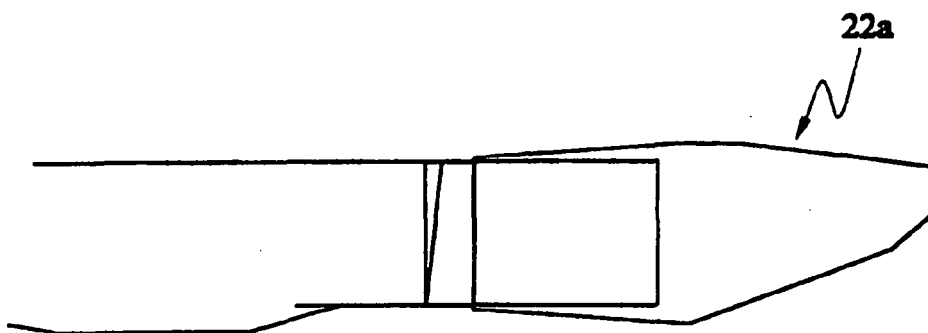

FIG. 7

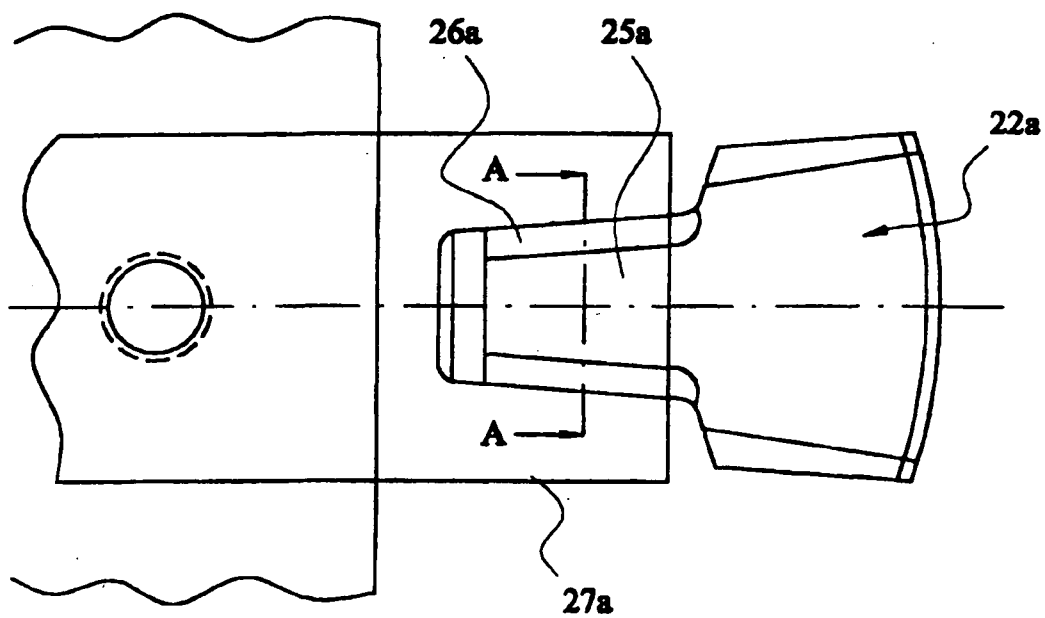

FIG. 6

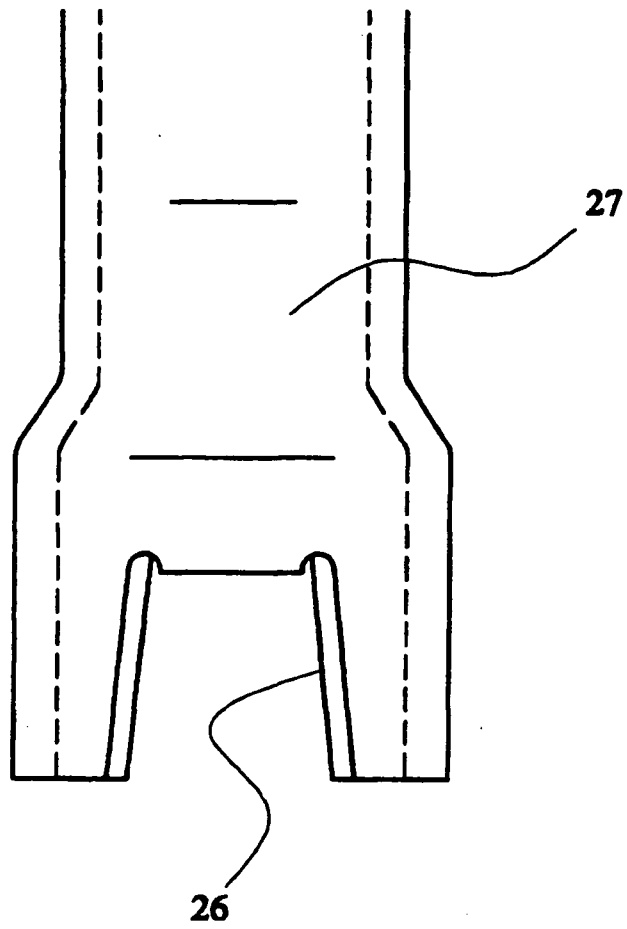

FIG. 9

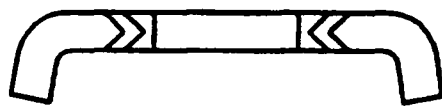

FIG. 10

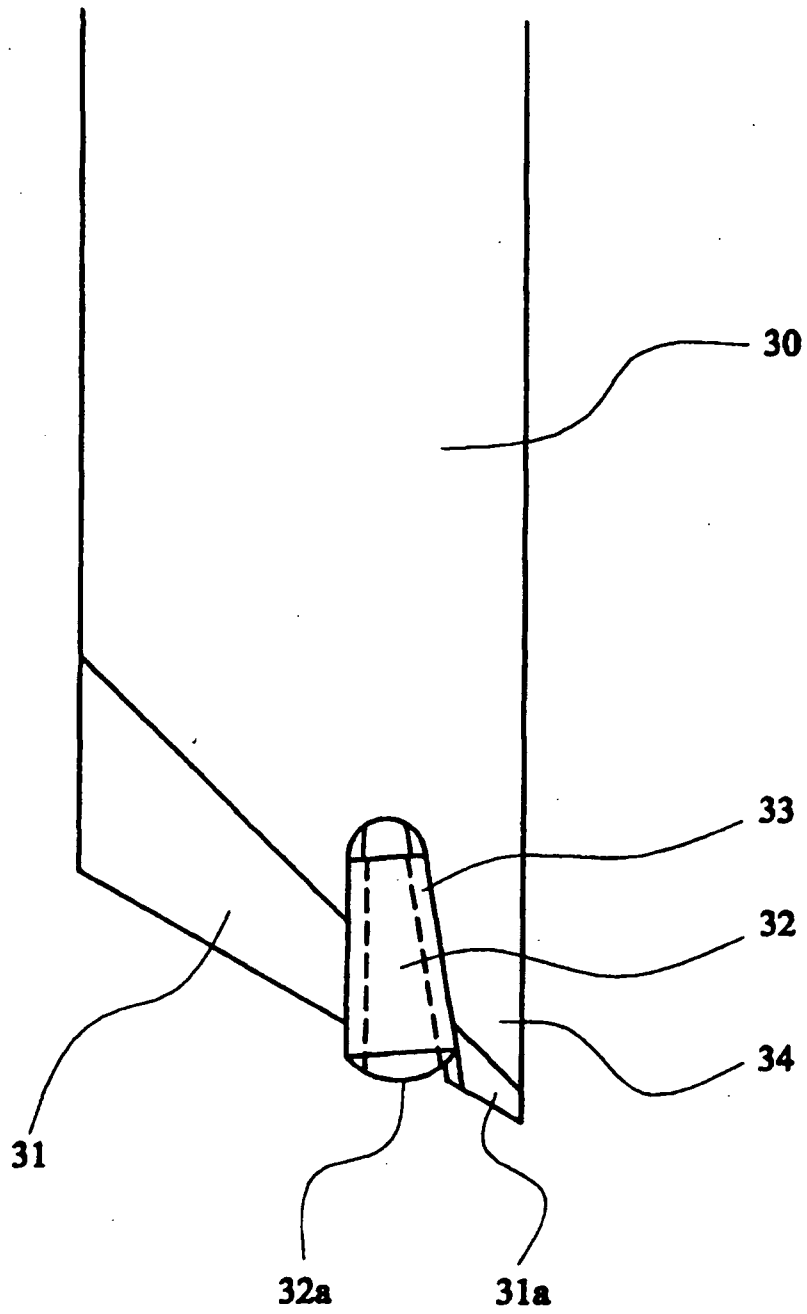
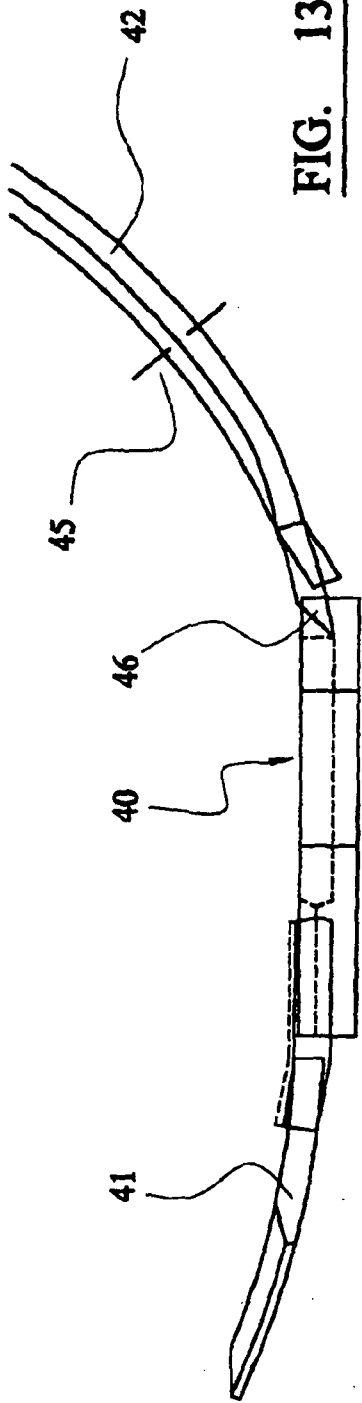
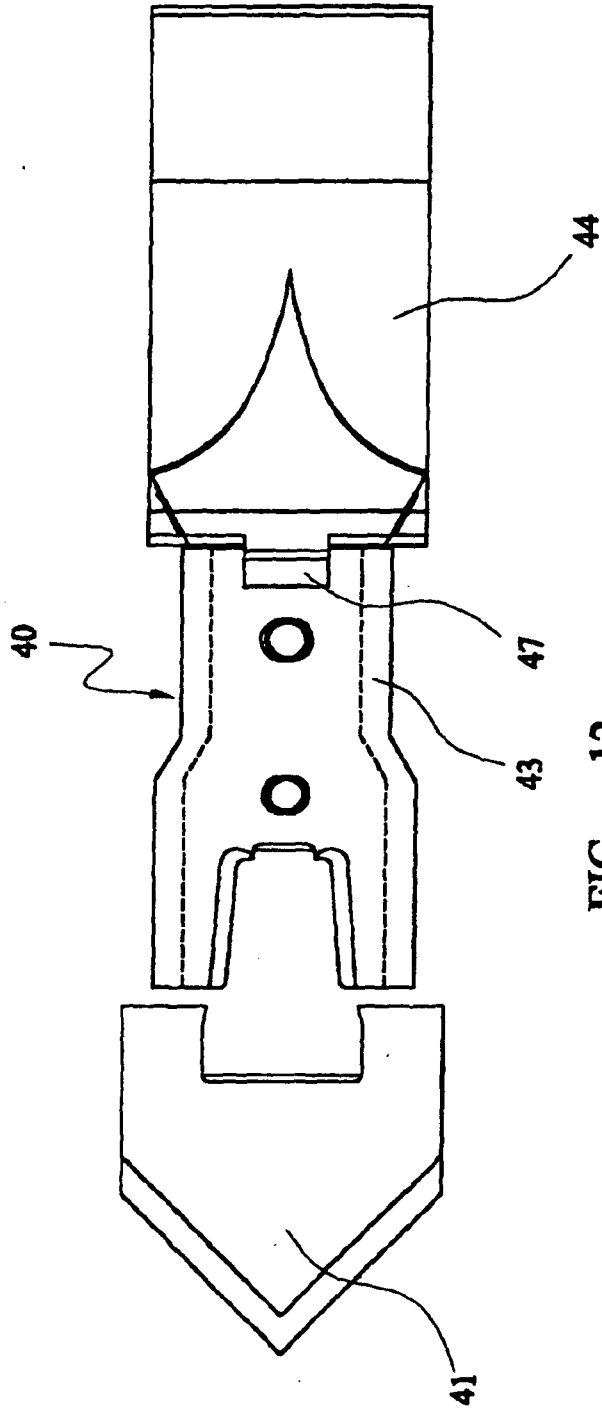

FIG. 11



**FIG. 13**



**FIG. 12**

**REFERENCES CITED IN THE DESCRIPTION**

*This list of references cited by the applicant is for the reader's convenience only. It does not form part of the European patent document. Even though great care has been taken in compiling the references, errors or omissions cannot be excluded and the EPO disclaims all liability in this regard.*

**Patent documents cited in the description**

- US 4754816 A [0001]